

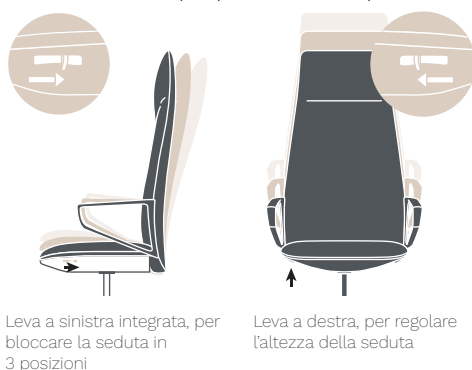

### CARATTERISTICHE TECNICHE

design J. Bennett & G. Ingignoli

schienale	disponibile sia alto che medio in poliuretano schiumato a freddo, flessibile (65 kg/m <sup>3</sup> ), ignifugo, esente da CFC, con inserto in acciaio.
sedile	in lamiera stampata con imbottitura in poliuretano flessibile ignifugo, esente da CFC; sottosedile con carter di copertura in polipropilene.
braccioli	in alluminio pressofuso di forma chiusa, trapezoidali, agganciati allo schienale. Le parti in alluminio possono essere lucidate o verniciate nere.
meccanismo	sincronizzato autotarabile, bloccabile in 3 posizioni. Angoli di oscillazione: 18° schienale, 1° sedile. Posizione di partenza del sedile: 1,5° indietro. Questo meccanismo Permette l'adattamento automatico al peso dell'utilizzatore senza richiedere alcuna operazione. La resistenza all'inclinazione dello schienale è direttamente proporzionale al peso esercitato sul sedile.



elevazione in altezza	mediante pompa a gas con leva integrata nel sottosedile. Consente un'escursione di 11 cm.
base	a 5 razze in alluminio disponibile nelle finiture alluminio lucido e verniciata con polveri epossidiche nere. Dotata di ruote piroettanti a doppio battistrada, gommate e autofrenanti (Ø 60 mm per versione alluminio lucido, Ø 65 mm per versione alluminio nero.)

ergonomia

Bia è dotata dei meccanismi necessari per un uso corretto e confortevole, anche per periodi prolungati, purchè siano soddisfatte le seguenti condizioni: la posizione di seduta standard richiede il mantenimento di angoli di 90° fra busto e coscia, fra coscia e gamba e fra gamba e piede. Questi due ultimi angoli sono essenziali affinché il piede, appoggiando completamente sulla superficie sottostante, scarichi su di essa parte del peso dell'arto inferiore, evitando un'eccessiva compressione sulla superficie posteriore della coscia e favorendo il ritorno verso il cuore del sangue circolante nelle vene della gamba.

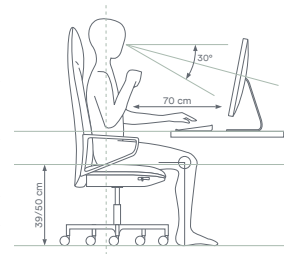

finiture base

-  Alluminio lucido
-  Alluminio nero









finiture braccioli

-  Alluminio lucido
-  Alluminio nero

tessuti

**Cat. D**

Skill (ecopelle)

















-  PGM3
-  PGTR
-  PGCD
-  PGTA
-  PGR1
-  PGCG
-  PGBZ
-  PGGB
-  PGVC
-  PGM2
-  PGNE

**Cat. F**

Step

-  STX2
-  STZ9
-  STSB
-  STE1
-  STBS
-  STVU
-  STE4
-  STE3
-  STE2
-  STNE















Chili

-  S0G6
-  S0G2
-  S0G3
-  S0M3
-  S0V2
-  S0R0
-  S0R4
-  S0RA
-  S0R7
-  S0R2
-  S0B9
-  S0B8
-  S0V5
-  S0V6
-  S0V7
-  S0NE

Stromboli

-  S8G0
-  S8M1
-  S8R1
-  S8R3
-  S8R2
-  S8B3
-  S8B2
-  S8B0
-  S8V2
-  S8NE

Silvertex

-  SBR7
-  SBV1
-  SBR3
-  SBR4
-  SBR5
-  SBR6
-  SBB7
-  SBB3
-  SBB6
-  SBG1
-  SBB1
-  SBM2
-  SBV4
-  SBV6
-  SBV3
-  SBG6















Valencia

-  SWR6
-  SWBI
-  SWV7
-  SWRA
-  SWR8
-  SWR3
-  SWR2
-  SWB8
-  SWG4
-  SWB9
-  SWB2
-  SWM6
-  SWG0
-  SWG8
-  SWG7
-  SWG1

Jet

-  JTW2
-  JTW3
-  JTH2
-  JTGM
-  JTYF
-  JT1R
-  JTRG
-  JTO1
-  JTR1
-  JTVM
-  JT07
-  JTVI
-  JTG3
-  JTV7
-  JTC1
-  JTV8
-  JTB3
-  JTZ6
-  JTM2
-  JTZ0

Magnum (ecopelle)

-  T5G7
-  T5B0
-  T5B6
-  T5B2
-  T5B5
-  T5R4
-  T5R6
-  T5V3
-  T5G1
-  T5M6
-  T5M5
-  T5G4
-  T5M3
-  T5V8
-  T5NE

Connect

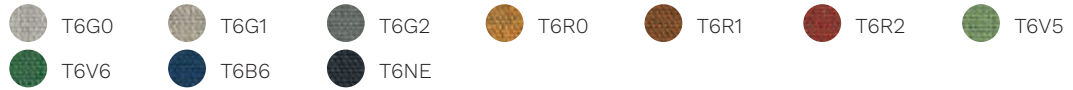

Rivet



Era



Go Check

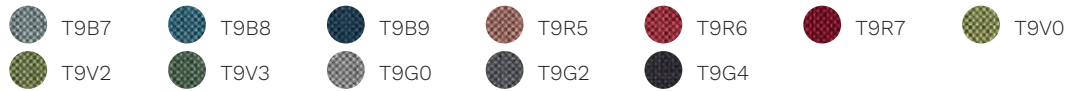

Rondo

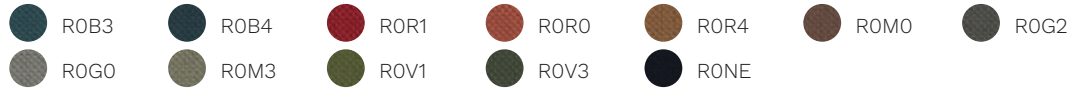

Cat. R

Disco Coex



Cat. G

Remix 3



Morph

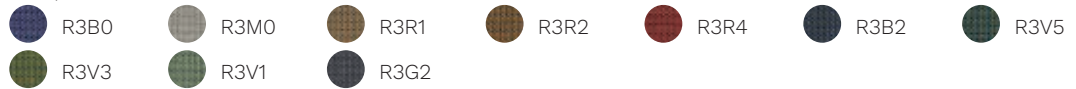

Focus

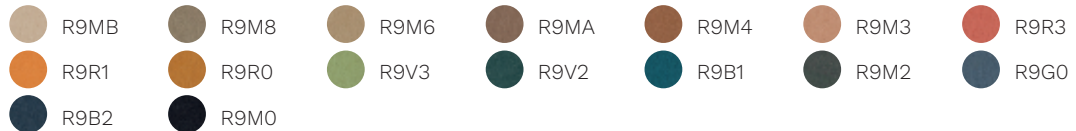

Focus Melange



Aida



### Cat. Q

Steelcut Trio 3



Ecriture

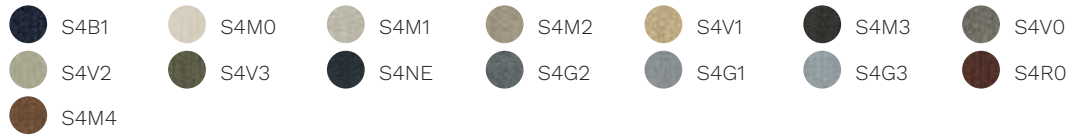

Ombra

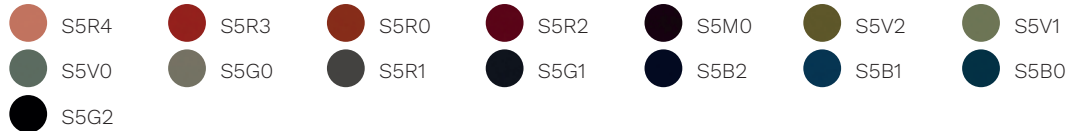

### Cat. P

Pelle



### Cat. PX

Pelle Fiore



### Cat. X

Elmosoft



Montana

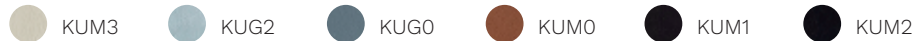

## ABACO

### Meccanismo sincronizzato 3 posizioni

Schienale alto.  
Elevazione a gas.

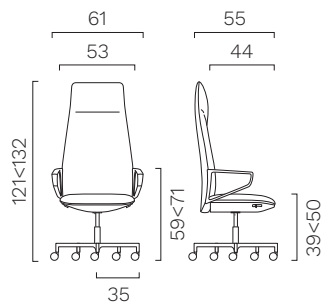

Schienale medio.  
Elevazione a gas.

